

V-RC8061 Pan and Tilt Video Camera

Description

The DMP V-RC8061 is an indoor wired/wireless remote pan and tilt, digital IP video camera that allows live view and recorded clips through the Virtual Keypad App, as well as email motion-triggered video clip notification. To install and activate the camera, you need an active dealer account at vk.securecomwireless.com.

Compatibility

- Any DMP system with an active Virtual Keypad App

What is Included:

- V-RC8061 Indoor Pan and Tilt Camera
- 5V Power Transformer (for 9' power extender, order V-DCEXT-9 separately)
- Mounting Screws
- Mounting Bracket

Assembling the Camera

Attach the camera to the stand if necessary for the installation.

Camera Configuration Options

The V-RC8061 can be configured to communicate to the SecureCom Video server in three ways:

Option #1 - Wired connection

Option #2 - Wireless connection using DMP V-IP1006RR Wireless Access Point (WAP) with WiFi Protected Setup (WPS)

Option #3 - Wireless connection using a WPS enabled WAP

Option #1 Configuration:

1. **IMPORTANT:** Before plugging in power to the camera, plug an Ethernet cable with an active internet connection into the Ethernet port.

Recommendation: We recommend marking the Ethernet cable from the customer's router to the WAP to help in network troubleshooting. If the end-user is having network issues after the install, you can instruct them to remove the marked Ethernet cable and see if the problem still exists. If it does, then they can contact their Internet service provider.

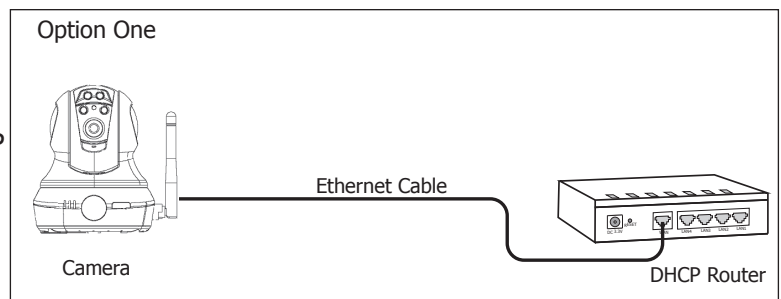

2. Once the Ethernet is plugged in, plug in the power adapter to the camera, and to a power outlet. The Power LED turns on solid during startup for 20 seconds. The Network and Power LEDs both start flashing while the camera is establishing a connection. Once it has a connection, the Power LED turns on solid, while the Network LED continues to flash to indicate network activity.

Option #2 Configuration:

For best results, establish communication while the WAP and cameras are no more than 20 ft from each other. After communication is established, place them in their desired location to ensure that they are still within wireless range of the WAP. Multiple WAPs can be installed for larger installations.

1. Plug in the power adapter to the camera, and to a power outlet. The Power LED turns on solid green for 20 seconds while powering up.

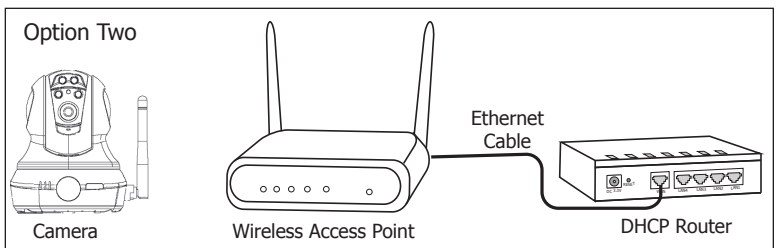

2. The Power LED will begin to flash when the camera is ready for WPS mode. Press the WPS button on the front of the WAP for 3 seconds. The Security LED will flash to indicate that the WAP is sending a security key to the wireless camera.

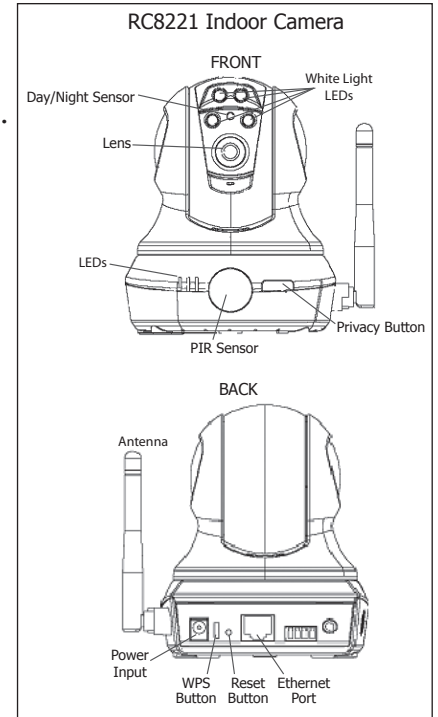

3. Within 1 minute of pressing the WPS button on the WAP, press and release the WPS button on the back of the camera. The Power LED turns solid, and the Network LED will begin to flash orange to indicate that it is setting up secure wireless communications. Once the camera and WAP are fully connected, the camera's Network LED will flash green, and the WAP's security LED turns on solid blue.

4. Repeat steps 1-3 for each camera you will be connecting at this site.

Note: All cameras must be paired with the WAP individually.

The camera is now ready to be activated through vk.securecomwireless.com.

Option #3 Configuration:

1. Plug in the power adapter to the camera, and to a power outlet. The Power LED begins to flash when fully powered on.

2. If using your own WPS-enabled WAP, refer to the WAP's instruction manual to put the WAP into the mode of sending a security key.

3. Within 1 minute of sending a security key, press and release the WPS button on the back of the camera. The Power LED turns on solid, and the Network LED begins to flash orange to indicate that it is setting up secure wireless communications. Once the camera and WAP are fully connected, the camera's Network LED will flash green, and the WAP's security LED turns on solid blue.

4. Repeat steps 1-3 for each camera you will be connecting at this site.

Note: All cameras must be paired with the WAP individually.

The camera is now ready to be activated through vk.securecomwireless.com.

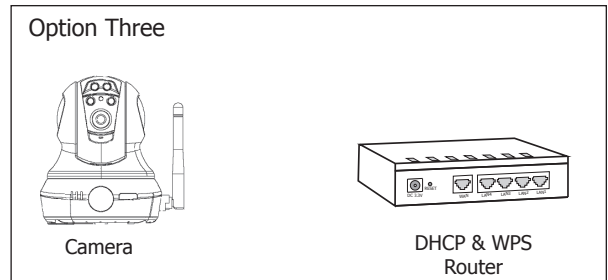

Activating a Camera through SecureCom Wireless

Once communication has been established, a camera can be activated at vk.securecomwireless.com

1. Login with your dealer login information at vk.securecomwireless.com and choose the correct customer.

2. Enable video on the customer's system by pressing on the edit button to the right of the account number of that system. See Figure 1.

This takes you to the system editing screen (Figure 2). Enable video by checking the video checkbox, and clicking Save. The System Profile screen will display.

3. From the System Profile screen, press Add New Camera. The New Camera screen (Figure 3) displays to enter the following information:

Name: The camera name that displays in the user's app. This can be 16 characters long.

Server Name or MAC Address: This information can be found on the back of the camera. If the MAC Address is listed, the 12 characters can be entered in this field. If the Server Name is listed, the 8 characters beginning with SC can be entered in this field.

Time Zone: Select the time zone of the camera location. This is used to indicate times of the clips.

Observe daylight savings time: Select Yes if your area observes daylight savings time. Default is Yes.

Ceiling Mount?: Select Yes if the camera will be mounted on the ceiling. Selecting Yes will correctly adjust the picture seen on the Virtual Keypad app.

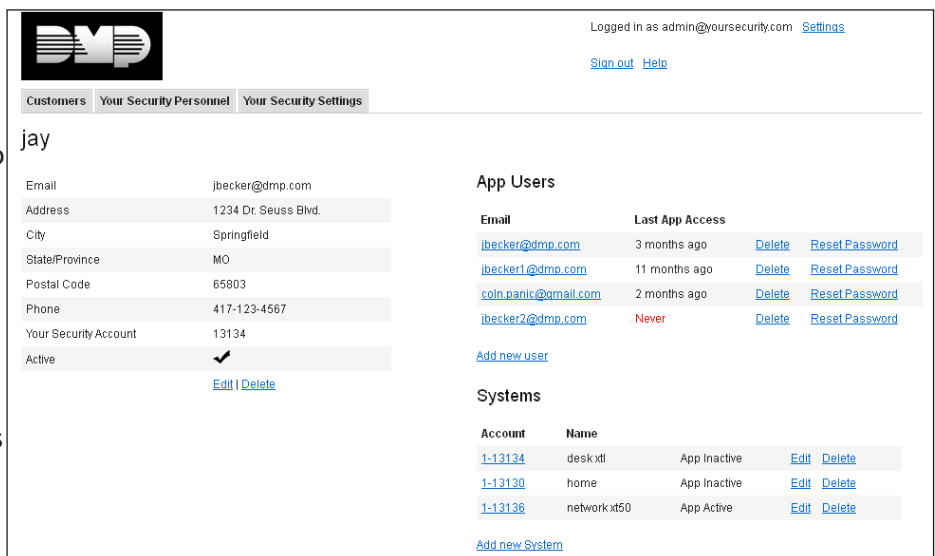

Figure 1: Customer Profile Screen

Figure 2: System Editing Screen

Figure 3: New Camera Screen

Clips: Enable Clips to allow this camera to record motion-triggered video clips to the SecureCom Video server.

- Choose Off if you only want this camera to offer a live camera view through the Virtual Keypad app.
- Choose On if you want this camera to record video clips any time it detects motion.
- Choose Scheduled if you want the camera to record motion-triggered clips using a time schedule. This allows you to add a schedule. You can choose to add one schedule for each day, or you can choose ‘Everyday’ or ‘Weekday’.

Shortest Time Between Video Clips: Each DMP video camera can record a video clip as frequently as every 3 minutes. To change from the 3-minute default, you can choose the 4 ,5, or 15 minute option. See Figure 3.

Once you have chosen the desired settings, clicking Save begins the activation process for this camera. You will see a status of ‘Activating’ next to the camera name. Press the refresh button to display the latest status. When the camera is active and communicating with the SecureCom Video Server, it will have a status of Active.

Viewing the Camera

To view the camera during installation, select the camera name on the Camera Profile Screen to display a live video feed for 60 minutes. This is to allow positioning of the camera to the user’s desired location. Once the 60 minutes has expired, the camera feed can only be seen through the user’s Virtual Keypad App.

Name	MAC Address	Server Name	Activation Status	
HD Aaron Desk	000E8F88C2B3	SC88C2B3	Active	Test Connection
OD Aaron Desk	000E8F92343A	SC92343A	Activating	
SD Aarons Desk	000E8F90F788	SC90F788	Active	Test Connection

[Add new camera](#) | [Refresh](#)

Figure 4: Camera Profile Screen

Emailing Clips

If the user would like to be emailed video clips, enable this option in the Editing User screen (Figure 5). From the Customer Profile Screen (Figure 1) click on the email address to go to the Editing User screen. Checking the Email video clips box sends emails with a video clip attachment to the App user any time the video camera records a video clip to the SecureCom video server.

Figure 5: Editing User Screen

Specifications

Sensor and Lens:

Image Sensor 1/4" CMOS Sensor
PIR Sensor 16 feet

Video:

Video Compression MPEG-4 SP, M-JPEG
Pan Range 320° (Left 160° - Right 160°)
Tilt Range 120° (Up 90° - Down 30°)
Frame Rate Up to 30 frames per second.

Network:

Wireless IEEE 802.11b/g;
WEP64/128 bit,
WPA/WPA2 Personal

Hardware:

Power Consumption 5V DC / Max 8W
Dimensions (HxWxD):
Camera 4.8" x 2.4" x 1.4"
Weight:
Camera 12.35 oz



800-641-4282

www.dmp.com

Made in the USA

INTRUSION • FIRE • ACCESS • NETWORKS

2500 North Partnership Boulevard

Springfield, Missouri 65803-8877