

**Triple Trunking
Mobile / Base Radio Scanner**

Thank you for purchasing your Triple Trunking Mobile / Base Radio Scanner from **RadioShack**. Your scanner scans conventional frequencies and trunked systems. Please read this user's guide before installing, setting up and using your new scanner.

What's Included

- | | | |
|----------------------------------|-------------------------|-------------------|
| Scanner | Antenna | Screw (2) |
| Mounting bracket | DIN sleeve and keys (2) | Rubber washer (2) |
| Lock washer (2) | Rubber feet (3) | Knob (2) |
| AC adapter | DC cable with fuse | User's Guide |
| Preprogrammed Frequency Addendum | | |



Contents

Your Scanner	4
Installing Your Scanner	7
Setting Up a Mobile Base	7
Bracket Mounting	7
Dashboard Installation	8
Connecting the Antenna.....	9
Powering Your Scanner	10
Headphones and Speakers.....	12
Keytones and Brightness.....	12
Delay	13
Squelch and Attenuator	13
Scanner Setup	14
Defining a Channel	15
Copying a Frequency	16
Deleting Saved Frequencies.....	17
CTCSS AND DCS.....	17
Scanner Cloning.....	18
Searching	19
Seek Search	19
Search Banks	19
Zeromatic.....	21
Programming a Search Range	21
Signal Stalker II.....	22
Locking Out Frequencies	23
Saving Found Frequencies.....	24
Scanning.....	25
Locking Out Channels.....	25
Priority Scanning	26
Weather Alerts	27
SAME Standby Mode	28
Skywarn.....	30

Monitoring	30
Trunking Setup	31
Defining a Trunking Bank	31
Trunking Modes	32
Motorola Trunking Setup	32
Base and Offset Frequencies	34
EDACS Trunking Setup	35
LTR Trunking Setup	36
Searching for Talk Group IDs	36
Saving a Talk Group ID	37
Deleting Talk Group IDs	38
Saving Trunking Channels	39
Trunk Scanning	39
Trunking Delay	40
Locking Out Talk Group IDs	41
Turning Off Sub-Banks	41
Talk Group ID Hold	42
Scanner Maintenance	42
Text Tags	43
Troubleshooting	45
Birdie Frequencies	46
Initializing the Scanner	47
Service and Repair	47
Scanning Legally	48
FCC Notice	49
References	49
Appendix A: Glossary	49
Appendix B: Search Banks	50
Appendix C: CTCSS / DCS Codes	54
Appendix D: Signal Stalker	55
Appendix E: Talk Group Format	57
Appendix F: Specifications	58

Your Scanner



Mounting
bracket



DIN sleeve
and keys (2)



DC cable w/fuse



AC adapter



Knob (2)



Rubber washer (2)



Lock washer (2)



Screw (2)



Rubber foot (3)



Antenna



1-9 / A-Z— Numbers and letters. Zero enters special characters.

./DELAY – Decimal point, space, delay functions.

ENT – Enter.

TRUNK — Accesses trunking functions.

L/OUT – Locks out channels, frequencies, or Talk Group IDs.

CLEAR

PROG – Program.

Squelch

VOLUME / OFF

FUNC — Function.

TUNE – Enters Tune mode.

ATT – Attenuator.

PAUSE

DIM – Dimmer.

WX/  — Weather search and Skywarn.

PRI – Priority.

TEXT – Activates text buttons.

MODE – Changes receive mode.

 — Signal Stalker.

SCAN — Starts a scan.

MAN — Manually select a channel or enter a channel number.

SRCH – Search.

▲▼ – Navigates functions.

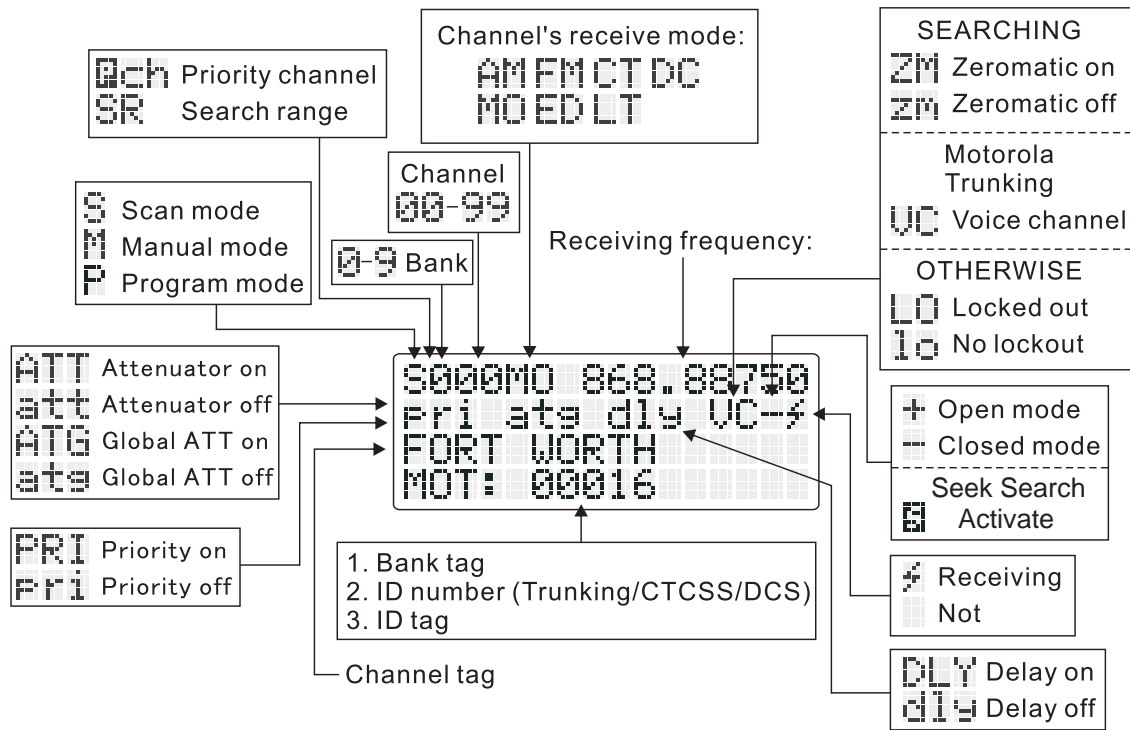
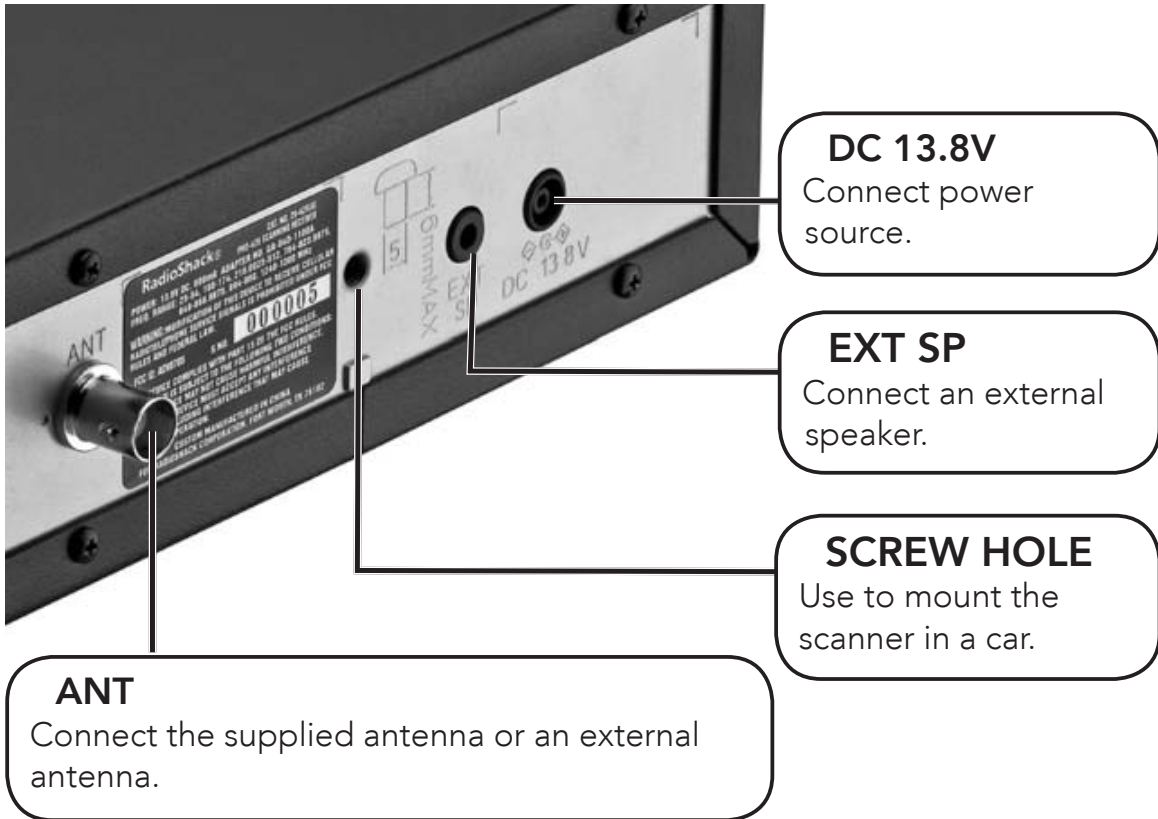

Installing Your Scanner

You can mount your triple trunking scanner in your vehicle or use it as a base station.

Setting Up a Mobile Base

You can place your scanner on a desk, shelf, or table to use it as a base station. Because the speaker is on the bottom of the scanner, you can use the mounting bracket to elevate your scanner off the surface for better sound.

To you use the scanner on a flat surface:

1. Attach the three protective rubber feet to the mounting bracket. Do not use them if you are mounting the bracket with screws.
2. Slide the scanner into the bracket, aligning the scanner's side holes with the holes in the bracket, and then screw the mounting knobs into the scanner.



Bracket Mounting

You can mount your scanner under or on top of the dashboard a desk, shelf, table or other flat surface, using the mounting bracket.

1. Use the supplied mounting bracket as a template to mark positions for the two mounting screws.
2. At the marked positions, drill holes slightly smaller than the screws.

When drilling holes, avoid obstructions behind the mounting surface.

-
3. Remove the paper backing from each washer and stick one inside of each bracket's ear, aligning the washer's hole with the bracket's hole.
 4. Attach the mounting bracket to your vehicle's surface using the supplied screws and lockwashers.



Dashboard Installation

If you are unsure how to install your scanner in your vehicle, consult your automobile manufacturer, dealer, or a qualified installer.

To mount in your dashboard, you must connect an external antenna and speaker.

1. Before installing, confirm your scanner fits in the desired mounting area and you have all the necessary materials. Your scanner requires a $2 \times 7\frac{1}{8} \times 5\frac{5}{16}$ inch (50 x 180 x 135 mm) space.
2. Remove the four rear screws and pull off the black case before installing your scanner.
3. Install the DIN sleeve into the opening in your dashboard, lip facing out.
4. Push out the top and bottom tabs to hold the sleeve firmly in place.
5. Slide the scanner into the sleeve until it locks in place.



To remove your scanner from the DIN sleeve, insert the two keys straight into the scanner's front panel and pull the scanner out.

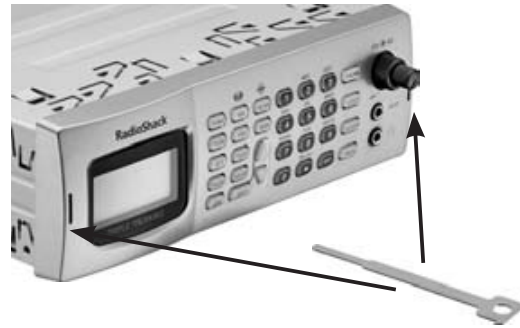

Connecting the Antenna

To connect an external antenna, always follow the installation instructions supplied with the antenna. Use 50-ohm, RG-58, or RG-8, coaxial cable. If the antenna is over 50 feet from the scanner, use RG-8 low-loss dielectric coaxial cable. If necessary, **RadioShack** carries a variety of adapters.

To attach the supplied antenna:

1. Align the antenna slots with the tabs on the scanner, and slide the antenna into place.
2. Turn and push down until the antenna locks into place.



Warning: Use extreme caution when installing or removing an outdoor antenna. If the antenna starts to fall, let it go! It could contact overhead power lines. If the antenna touches a power line, touching the antenna, mast, cable, or guy wires can cause electrocution and death. Call the power company to remove the antenna. DO NOT attempt to do so yourself.

Powering Your Scanner

You can power your scanner from a wall outlet, or from your vehicle's battery.

*You must use a power source that supplies 12V DC and delivers at least 600 mA. Its center tip must be set to positive and its plug must fit the scanner's **DC 13.8V** jack. The supplied AC adapter and DC power cord meet these specifications. Using a power source that does not meet these specifications could damage the scanner or the adapter.*

Wall Outlet

1. Connect the tip of the supplied AC adapter to the DC 13.8V jack at the rear of your scanner.
2. Plug the AC adapter into your wall outlet.



To prevent electric shock, do not use the AC adapter's polarized plug with an extension cord, receptacle, or outlet unless you can fully insert the blades to prevent blade exposure.

To avoid injury, do not connect the provided power adapter to a ceiling outlet.

Vehicle (Power Socket)

To power your scanner from a 12V power source in your vehicle, such as a cigarette-lighter socket, you need a 12V, 600 mA DC cigarette-lighter adapter (not supplied), available at your local RadioShack store.

1. Insert the adapter's barrel plug into the scanner's **DC 13.8V** jack.
2. Plug the adapter's other end into your vehicle's cigarette lighter or power socket.

When you use a cigarette-lighter adapter, you might hear electrical noise from your engine while scanning. This is normal.

Vehicle (Direct)

1. Disconnect the cable from your vehicle battery's negative (-) terminal.
2. Ground the black wire of the supplied DC power cord to your vehicle's chassis. The grounding screw must make complete contact with your vehicle's metal frame.
3. Connect the red wire of the supplied DC power cord to a voltage source that turns on and off with the ignition switch, such as a spare accessory terminal in your vehicle's fuse box.
4. Insert the power cord's barrel plug into the scanner's **DC 13.8V** jack.
5. Reconnect the cable to your vehicle battery's negative (-) terminal.



Headphones and Speakers

You can plug headphones or speaker (neither included) into your scanner.

To use headphones, connect the plug into the headphone jack on the front panel. Headphones automatically mute the scanner's speaker.

To use external speaker, connect the plug into the EXT SP jack on the rear panel.

Even though some earphones/headphones let you hear some outside sounds when listening at normal volume levels, they still can present a traffic hazard.

To protect your hearing, follow these earphone or headphones guidelines:

- Do not listen at extremely high volume levels. Extended high-volume listening can lead to permanent hearing loss.
- Set the volume to the lowest setting before listening. Turn on the scanner, and adjust the volume to a comfortable level.
- After you set the volume, do not increase it. Over time, your ears adapt to the volume level, so a volume level that does not cause discomfort might still damage your hearing.
- Do not wear headphones while driving. This can create a traffic hazard and is illegal in some areas.

Keytones and Brightness

Your scanner features a backlit keypad and display for easy viewing and sounds a tone each time you press a key.

To set the keytone:

1. Turn on the scanner. "Multi-system Trunking Scanner" appears.
2. While "Multi-system Trunking Scanner" appears, press **1** to turn on the keytone or **2** to turn it off.

To change the backlight mode:

Repeatedly press **DIM** to adjust display backlight brightness from Dark, Light off, or Light.

Delay

Sometimes, several seconds can pass between transmissions. To avoid missing a reply, a delay is automatically set for each channel. The scanner stops for 2 seconds after a transmission stops before it resumes scanning or searching.

To turn the delay on / off:

1. Press **./DELAY**. **DLY** appears if the delay is on.
2. To turn on the delay, press **./DELAY** again. "dly" appears if the delay is off.

Squelch and Attenuator

The squelch and attenuator control the scanner sensitivity. If you hear a hissing sound, the scanner will remain on the current channel.

To set squelch:

1. Turn off the scanner and turn **SQUELCH** fully counterclockwise.
 2. Turn on the scanner. You should hear a hissing sound. If you set the squelch precisely at the threshold where the hiss stops, the scanner may pick up unwanted or very weak transmissions. To prevent this, set the squelch past this threshold.
 3. Turn the **SQUELCH** clockwise to decrease the scanner's sensitivity, turn counterclockwise to increase its sensitivity.
-

With the attenuator on, the scanner might not receive weak signals. You can reduce interference using two attenuator modes:

- Global – (Default) The attenuator setting is applied to all channels, bands, or groups.
- Normal – Lets you set the attenuator in each channel, band, or group.

You cannot set the attenuator while scanning.

To set the attenuator mode:

1. To set Global mode, press **FUNC** and then **ATT**. On the display "G" appears."
2. To set the attenuator for each channel, press **FUNC** and then **ATT**. On the display "G" disappears. For each channel:
 - On – Press **ATT**. "A" appears.
 - Off – Press **ATT** again. "A" disappears."

Scanner Setup

A **frequency**, expressed in kHz or MHz, is the tuning location of a station.

Your scanner saves frequencies to **channels** and groups the channels into banks. The scanner's 10 **banks** each hold 100 channels (1,000 channels total).

The scanner is preset to the most common AM or FM receive modes for each frequency range. However, some amateur transmissions may operate in a different mode. If the transmission sounds weak or distorted, you may have the channel set to the wrong **receive mode**:

AM – Amplitude Modulation, primarily used for aircraft, military, some amateur and government transmissions.

FM – Frequency Modulation, used for most public safety transmissions, broadcast, business, and amateur radio transmissions.

CT – FM transmissions with Continuous Tone Coded Squelch System (CTCSS)

DC – FM transmissions with Digital Coded Squelch (DCS)

MO – Motorola Trunking System

ED – EDACS Trunking System

LT – LTR Trunking System

*If you change the receive mode using **MODE** key, the scanner shows the receive mode for small caps (ex. fm, am, ct, or dc). If you want to change the default setting, press **FUNC** then press **MODE**.*

Defining a Channel

Go to www.radioreference.com for the latest frequency references.

To define a channel:

1. Press **MAN**.
2. Enter the bank (0-9) and channel number (00-99) where you want to store the frequency (Example: 101 for Bank 1, Channel 1).
3. Press **MAN** again. M and the bank and channel number appear.
4. Press **PROG**. M changes to P.
5. Use the number keys to enter the frequency (including the decimal point). If you make a mistake, press **CL** to delete a single digit or hold **CL** about 2 seconds to start over.

Your scanner automatically rounds to the nearest valid frequency. For example, if you enter 151.553, your scanner rounds to 151.550.

-
6. If necessary, press **MODE** to change the receiving mode.
 7. Press **ENT**.
If the frequency is already stored in the bank, "Dupl.Freq. ChXXX" appears. To copy the duplicate frequency anyway, press **ENT** or press **CL** to cancel.
If you made a mistake in Step 5, "Invalid Freq." briefly appears and the scanner beeps when you press **ENT**. Go back to step 5 again.
 8. Press **MAN** again. M and the bank and channel number appear.
For information about adding text tags to a channel or bank, see "Text Tags" on Page 43.

Copying a Frequency

When you copy a frequency, all the channel conditions, including mode, are also copied.

To copy a frequency:

1. Press **TUNE**.
2. Tune the frequency you want to copy.
3. If necessary, press **MODE** to change the receiving mode.
4. Press **FUNC** then **ENT**. "Bank 9 Store?" appears.
5. To select a new bank, press the bank number.
6. Press **ENT**. "Channel Stored!" appears briefly.
If the frequency is already stored in the bank, "Dupl.Freq. ChXXX" appears. To copy the duplicate frequency anyway, press **ENT** or press **CL** to cancel.
7. Press **MAN**.

Deleting Saved Frequencies

To delete a saved frequency:

1. Press **MAN**.
2. Use the number keys to enter the frequency's channel number.
3. Press **MAN**.
4. Press **PROG**. M changes to P.
5. Press **FUNC**.
6. Press **CL**. "0.0000" appears.

To delete all saved frequencies in a bank:

1. Press **PROG**. M changes to P.
2. Press **FUNC**.
3. Use the number keys to enter the bank number.
4. Press **FUNC** then **CL**. "Clear entire bank?" appears.
5. Press **1** to clear all. Any other key aborts.

CTCSS AND DCS

CTCSS and DCS allow multiple users to share a single radio frequency without hearing each other's transmissions. Your scanner features an advanced, CTCSS and DCS decoder that displays CTCSS or DCS codes when available.

To define a channel's CTCSS or DCS code:

1. Press **PROG**. M changes to P.
2. Navigate to the channel.
3. Enter a conventional frequency.
4. Press **MODE** until the desired mode (CT or DC) appears with the default search code value.

-
5. Press **FUNC**, then **MODE**.
 6. Use the ▲ or ▼ to select the desired CTCSS or DCS code.
You can enter the code manually. The scanner automatically fills in the code. See Appendix B for a list of codes.
 7. Press **ENT**.

To save a CTCSS or DCS code:

Press **ENT** while the code appears.

Scanner Cloning

You can transfer the programmed data to and from another PRO-163 (or PRO-164) scanner using a connecting cable which has 1/8-inch stereo (TRS) phone plugs on both ends (not supplied).

You can also upload or download the programmed data to or from a PC using an optional USB cable and application software available through your local **RadioShack** store. The application software is also available online at www.starrsoft.com and www.scancat.com.

To clone the scanner data:

1. Turn on both scanners.
2. Connect the connecting cable to each scanner's **PC/IF** jack. ** CLONE MODE ** appears.
3. Press ▲. "Confirm to send data?" appears.
4. Press **1** to send the data to the other unit or press any other key to cancel.
5. To exit the clone mode, remove the cable.

"CLONE MODE Incorrect Model" appears if you connect a scanner other than a PRO-163 (or PRO-164).

Searching

You can search for transmissions using the preprogrammed search bank, which is divided into eight search bands.

Seek Search

When Seek Search is active, the scanner stops on active frequencies for five seconds and then resumes searching automatically.

To activate Seek Search:

1. Press **FUNC** then **7**. "Seek Search ON" appears briefly and "S" appears on the display.
2. To turn off Seek Search, press **FUNC** then **7** again. "Seek Search OFF" appears briefly.

Search Banks

To search preprogrammed search banks:

1. Press **SRCH** repeatedly to select a bank.

Bank	Band
SR0	Marine
SR1	CB
SR2	FRS/GMRS/MURS
SR3	Public Safety
SR4	Aircraft
SR5	Amateur Bands
SR6	Railroad
SR7	Limit search (User changeable)

SR3 to SR5 banks contain several groups. To turn off a group, press the group number; the group number disappears. To turn the group back on, press the group number again.

2. Adjust the Squelch. After the set delay, the scanner starts searching. When the scanner finds an active frequency, it stops searching.
3. To pause while searching, press **PSE**. The scanner stops searching and ***** PAUSED ***** appears. To resume, press **PSE** again.
4. If the scanner stops on an unwanted frequency, you can press **L/OUT** to lock out the frequency.

In the SR6 Railroad and SR7 Limit search bands, press **FUNC** then **▲** or **▼** to start searching up from the lowest or down from the highest frequency.

To search banks SR0-SR2:

1. Press **SRCH** repeatedly to select SR0, SR1, or SR2.
2. To search the entire band, press **FUNC** then **SRCH**. "MAN" (Manual select) or "SRCH" (searches through the band) appears.
The scanner starts searching and "SRCH" appears on the display. When the scanner finds an active frequency, it stops searching.
Press **FUNC** then **SRCH** again to return to the previous mode.
3. To select a channel while "MAN" appears on the display, press a channel number or use **▲** or **▼**.
4. Adjust the Squelch.
5. If the scanner stops on an unwanted frequency, you can press **L/OUT** to lock out the frequency. For more information, see Locking Out Frequencies....
6. To pause while searching, press **PSE**. The scanner stops searching and ***** PAUSED ***** appears. To resume, press **PSE** again.

Zeromatic

While searching, the scanner stops if a transmission triggers the squelch setting. A narrow-band FM transmission can have a deviation of +/- 5 KHz, and the actual total bandwidth, including the tails of the sidebands, can be even greater. However, search intervals smaller than that can stop your scanner short of the correct (center) frequency.

The Zeromatic function allows the scanner to find the correct center frequency for search banks SR3, SR4, SR5, SR6 and SR7. Zeromatic automatically tunes the step-increment frequency closest to the center frequency.

To activate Zeromatic:

1. Press **FUNC** then **0**. "Zeromatic ON." appears briefly, then ZM appears.
2. To turn Zeromatic off, press **FUNC** then **0** again. "ZM" changes to "zm."

Programming a Search Range

To program the search range of Bank SR7:

1. Repeatedly press **SRCH** to select SR7.
2. Press **PROG** then **SRCH**. "Enter SR7 Search Range Limits" appears. L blinks for the lower-limit of the range.
3. Use the number keys to enter the lower-limit frequency (including the decimal point).
4. Press **ENT**. U appears.
5. Use the number keys to enter the upper-limit frequency (including the decimal point), then press **ENT**.

If either entered frequency is incorrect, "Invalid Freq" appears briefly.

-
6. Press **SRCH** to start searching.
 7. Adjust the Squelch. After the set delay, the scanner starts searching. When the scanner finds an active frequency, it stops searching.



Signal Stalker II

Signal Stalker II provides a powerful tool to rapidly detect, monitor and save frequencies of nearby or high-power transmissions. Signal Stalker II resembles more expensive portable frequency counters, but provides many advantages over typical portable frequency counters.

Signal Stalker II is more sensitive than portable frequency counters and will detect transmissions at a greater distance. Signal Stalker II rapidly searches the RF spectrum in 1 MHz segments. If it detects a signal, Signal Stalker II searches in finer steps until the signal source is found.

Signal Stalker II can search all frequencies, or you can define frequency ranges, to avoid ranges with constant activity, such as paging or broadcast transmitters.

To use Signal Stalker II:

1. Hold the Signal Stalker button () for approximately 1 second.
2. To change the scanned band (All Band or Police/Fire), press FUNC then Signal Stalker (). For a list of Signal Stalker Bands, see Appendix D.
3. To turn off a bank, press the bank or group number while Signal Stalker II is active.
4. To turn off Signal Stalker, hold the Signal Stalker button () again.

Priority mode is not available while using the Signal Stalker II.

Special Signal Stalker

Special Signal Stalker II divides the frequency range by 1 MHz segments. If you lock out 5 frequencies within 1 MHz segment, the scanner will skip that segment in subsequent sweeps.

To use Special Signal Stalker II:

1. Press **FUNC**.
2. Use ▲ or ▼ to select "Sp. Stalker" appears for Special Signal Stalker II.
3. To turn off Special Signal Stalker II, press **FUNC** and then ▲ or ▼ again.

Locking Out Frequencies

When you lock out frequencies during a search, the scanner continues searching, but ignores the locked out frequencies. You can lock out up to 50 frequencies in each bank. If you try to lock out more, "L/O Memory Full!" appears.

While using Signal Stalker II, you can lock out 150 frequencies if searching all bands and 50 frequencies while searching PubSafety frequencies. If you lock out 5 frequencies within a 1 MHz segment, the scanner will skip that segment in subsequent sweeps.

If you lock out all the frequencies in a search bank and only that search bank is activated, "All ranges Locked out!" appears and the scanner does not search.

Signal Stalker II still performs a fine step search for locked out signals. Signal Stalker II will not stop on the signal, but scan may take longer.

To lock out a frequency:

When the scanner stops on a frequency, press **L/OUT**.

To review and unlock frequencies:

1. Press **SRCH** to enter search mode.
2. Press **FUNC** then **L/OUT**. The first locked-out frequency and lockout list appear. If the search bank has no locked-out frequencies, "No Lockout" appears.
3. Press **▲** or **▼** to review the list. The current position and the total locked-out number also appear as "Lockout XX of YY." (Example: Lockout 10 of 30.)
4. (Optional) To unlock a frequency, select the frequency then press **CL**.
5. Press **FUNC** then **L/OUT** again to exit.

To unlock all frequencies in a search bank:

1. Press **SRCH**.
2. Select the search bank.
3. Press **FUNC** then press **L/OUT**. The Lockout list appears.
4. Press **FUNC** then **6**. "Clear entire list?" appears.
5. Press **1**. "List cleared" appears. Pressing any other key cancels the clearing.

Saving Found Frequencies

To save a frequency found during a search:

1. When the scanner stops on a frequency, press **FUNC** then **PROG**. "Store in ChXXX?" appears and the frequency flashes.
2. To change the target channel, enter the bank and channel number.
3. Press **ENT**. "Channel Stored!" appears briefly, then the search resumes.

Scanning

Scanning sequentially checks all saved channels for activity. You must save frequencies into channels to scan. The scanner does not scan empty channels or unsaved frequencies.

You can increase the scanning speed by locking out channels with continuous transmissions, such as a weather channel or turning off entire banks. Turning off a bank prevents the scanner from scanning any channels within the bank. You cannot turn off all banks. There must be at least one active bank to scan.

To scan:

1. Press **SCAN**. The scanner checks all unlocked channels in the active banks. To change the scan direction, press ▲ or ▼.
2. To stop on a channel, press **PSE**.
3. To lock out a channel, when the scanner stops on the channel, press **L/OUT**.
4. To turn off a bank, press the bank's number so the bank's number disappears. To turn on a bank, press the number key so the bank's number appears.

Locking Out Channels

You can increase the scanning speed by locking out channels with continuous transmissions.

To locked out a channel:

1. Press **MAN**.
2. Enter the bank and channel number or use ▲ or ▼ to select the channel.
3. Press **L/OUT**. "lo" changes to "LO."
4. To unlock a locked-out channel, press **L/OUT** again.

To review all locked out channels:

1. Press **MAN**.
2. Repeatedly pressing **FUNC** and then **L/OUT** to view each locked-out channel.
3. To unlock a channel, press **L/OUT**. "LO" changes to "lo."
4. When you finish reviewing locked-out channels, press **MAN**.

You can manually select any channel in a bank, even in turned-off banks.

Priority Scanning

In addition to the 1,000 programmable memory channels, your scanner has one Priority channel. When Priority is turned on, the scanner checks the Priority channel every 2 seconds. This lets you scan without missing a transmission on the Priority channel.

*Priority scanning does not operate for trunking transmissions.
Priority check can seem random during peak hours.*

To turn on the priority feature:

1. Press **PRI** so "pri" changes "PRI" on the display during scanning.
2. To turn off Priority, press **PRI** again.

To make an existing channel a Priority channel:

1. Press **MAN**.
2. Use the number keys to enter the bank and channel number.

The Priority channel cannot be a trunking channel (MOT, ED, or LTR).

3. Press **MAN**.
4. Press **FUNC**, then hold **PRI** until the display blinks.

To modify the Priority channel:

1. Press **PROG**.
2. Press **PRI**.
3. Use the number keys to enter the frequency.
4. Press **ENT**.

If the frequency is incorrect, "Invalid Freq" appears briefly.

Weather Alerts

The Federal Communications Commission (FCC) has allocated channels for use by the National Oceanic and Atmospheric Administration (NOAA). NOAA broadcasts Specific Area Message Encoding (SAME) alerts that include digitally encoded data about the severity of the alert.

Regulatory agencies in other countries have also allocated channels for use by their weather reporting authorities.

If you program a weather channel as the Priority channel, your scanner can detect the 1050 Hz weather alert tone. All alerts are received (FIPS settings are ignored), and the scanner stays on the Priority channel only if the scanner detects a weather alert.

To perform a weather scan:

Press **WX**. Your scanner scans through the weather bands then stops on the next available weather broadcast.

To program a weather channel into priority channel:

1. Press **WX**.
2. Select the weather channel.
3. Press **FUNC** and then **PRI**.

SAME Standby Mode

SAME alerts include FIPS codes to identify areas, established by the US Census bureau. You can set your scanner to alert for all areas or limit weather alerts to up to 10 specific areas by FIPS code.

The National Weather Service maintains a current list of FIPS codes at www.nws.noaa.gov/nwr/.

To program a FIPS code:

1. Press **WX** and listen to identify the weather station with the strongest signal.
2. Press **FUNC**, and then **PROG** to access the FIPS code entry table.
3. Use **▲** or **▼** to select the desired FIPS code storage location.
4. Use the number keys to enter the FIPS code. The format of a FIPS code is:

Subdivisions	State Code	County Code
0-9 (0=entire area)	01-50 (00=all states)	XXX (000=all counties)
Example: 048439 (0=All; 48=Texas; 439=Tarrant County)		

5. (Optional) To label the code, press **TEXT** and use the letter buttons to enter text.
6. Press **ENT** to store the code. Repeat this process to program additional FIPS codes.
7. Press **L/OUT** to lock out or enable specific FIPS entries.
8. Press **WX** to exit the FIPS code entry table.

To review stored FIPS codes:

1. Press **WX** then a number key.
2. Press **L/OUT** to change the lockout status.

For information about adding text tags to a FIPS code, see "Text Tags" on Page 43.

To enter SAME standby:

1. Press **FUNC**, and then **WX**. The scanner will monitor the selected weather radio station for alerts with FIPS codes that match the codes you entered in the FIPS entry table.
2. To exit SAME standby, press **FUNC**, and then **WX**.

The scanner searches the weather frequencies while in SAME standby mode when squelch is off.

The scanner sounds an alert or beep when it receives the SAME code. After five minutes, the alert stops and the scanner beeps every ten seconds.

3. Press any key except **DIM** to reset the scanner.

To test the weather alert:

1. Press **WX**. Your scanner scans through the weather bands.
2. Set the Squelch to the lowest setting so that you hear static.
3. Press **FUNC** and then **WX**. "SAME Standby" appears.
4. Hold **ENT** for about 2 seconds. The display indicates the type of message, and the scanner sounds an alert or series of beeps.
5. Press any key except **DIM** to stop testing.

Skywarn

Skywarn is an organized group of trained weather observers. Using Skywarn, you can hear trained observers in your area call in official reports to a control station that relays those reports to NOAA and other emergency agencies.

Before using this feature, save local Skywarn frequencies for your area into Channel 999.

To use Skywarn:

Hold the Skywarn button (). "SKY" appears.

If the skywarn channel is empty, "Not programmed" appears.

Monitoring

When *monitoring*, the scanner remains on a single channel.

Your scanner features a power save circuit that allows the scanner to "sleep" briefly while waiting for a call on a monitored channel.

To monitor a channel:

1. Press **MAN**.
2. Use the number keys to enter the channel number and press **MAN**.

To find a frequency to monitor:

1. Press **TUNE**. The currently-tuned frequency and *** PAUSED *** appear.
2. (Optional) Use the number keys to change the frequency and press **ENT**.
3. Press **PSE**. The scanner searches for a frequency. To change the

tune direction, press ▲ or ▼. When the scanner finds an active frequency, it stops.

4. Press **PSE** to monitor the frequency.

The transmission signal level is indicated by the 5 dots.

To set a default tuning frequency:

1. Press **MAN**.
2. (Optional) Use the number keys to enter the frequency number.
3. Press **FUNC**, then **TUNE**. The scanner saves the frequency. For example, if you save 145.31000 MHz, when you press **TUNE**, the scanner starts tuning at 145.31000 MHz.

Trunking Setup

Instead of transmitting on a specific frequency, trunking systems choose one of several frequencies during a 2-way radio transmission and simultaneously transmit a Talk Group ID that identifies the 2-way radio user. This allows trunking systems to allocate fewer frequencies to multiple 2-way radio users.

Defining a Trunking Bank

You can define any of the 10 banks as a trunking bank, but each bank can only scan for one system: Motorola, EDACS (GE/Ericsson), or LTR (EF Johnson).

Trunking banks can contain both trunking and non-trunking channels.

To define a Trunking Bank:

1. Press **PROG**, then press **TRUNK** to enter the ID program mode.
2. Press **FUNC**, then use ▲ or ▼ to select a bank.

-
3. Repeatedly press **MODE** to select a trunking mode (Motorola, EDACS, or LTR).
 4. Press **PROG**.

Trunking Modes

In **Closed** mode, the scanner stops only on transmissions with saved and unlocked Talk Group IDs. This lets you focus a scan on the frequencies you have identified, ignoring other transmissions.

In **Open** mode, the scanner stops for transmissions on any unlocked channel. This lets you search for Talk Group IDs that you can then save.

While scanning, “-” appears for Closed mode and “+” appears for Open mode under the channel storage bank’s number. When the scanner stops on a channel, “OPEN” or “CLOSED” appears.

To set Open or Closed mode for a bank:

1. Press **MAN**.
2. Use ▲ or ▼ to select a bank.
3. Press **FUNC** then **DELAY**. “Bank OPEN” or “Bank CLOSED” appears.

Motorola Trunking Setup

Motorola systems can allocate as few as five frequencies to up to several thousand groups of users in three categories:

- Type I – User groups are assigned to fleets. To scan, you must program a fleet map into the scanner.
- Type II – The Talk Group ID contains 4 or 5 digit numbers.
- Hybrid – Combines Type I and Type II formats.

Fleet Maps

For Motorola Type I and hybrid systems, you must program a fleet map before saving Talk Group IDs.

To program a fleet map:

1. Press **PROG** then **TRUNK**.
2. Press **FUNC**, then press ▲ or ▼ to select the bank.
3. If necessary, repeatedly press **MODE** to select "Motorola."
4. Press **FUNC**, then press **8**. "Size Code Setting" appears, with Block 0 selected.
5. Enter the size code for Block 0, supplied with the Type I system information, or try one of the following common fleet maps.

Size Codes	BLOCKS							
	0	1	2	3	4	5	6	7
1	S11	S11	S11	S11	S11	S11	S11	S11
2	S4	S4	S4	S4	S4	S4	S4	S4
3	S4	S4	S4	S4	S4	S4	S12	—
4	S12	—	S4	S4	S4	S4	S4	S4
5	S4	S4	S12	—	S4	S4	S4	S4
6	S3	S10	S4	S4	S12	—	S12	—
7	S10	S10	S11	S4	S4	S4	S4	S4
8	S1	S1	S2	S2	S3	S3	S4	S4
9	S4	S4	SO	SO	SO	SO	SO	SO
10	SO	SO	SO	SO	SO	SO	S4	S4
11	S4	SO	SO	SO	SO	SO	SO	SO
12	SO	SO	SO	SO	SO	SO	SO	S4
13	S3	S3	S11	S4	S4	SO	SO	SO
14	S4	S3	S10	S4	S4	S4	S12	—
15	S4	S4	S4	S11	S11	SO	S12	—
16	S3	S10	S10	S11	SO	SO	S12	—

For Motorola Type II, enter 15.

6. Press **ENT**. The next block appears.
7. Repeat steps 5-6 for each block. If you make a mistake, press **CL** and enter the correct size code.

Base and Offset Frequencies

To receive Motorola VHF and UHF system transmissions, you must program applicable *base* and *offset* frequencies. In the 800 MHz trunking band, you can select a base frequency (normal or offset), but in the 900 MHz trunking band, you do not need to set the base frequency.

You can get information about base and offset frequencies from www.trunkscanner.com.

UHF-Lo (406-512 MHz)

To program Motorola base and offset frequencies:

1. Press **PROG** then **TRUNK** to enter the ID program mode.
2. Press **FUNC**, then press ▲ or ▼. The bank number increases or decreases by one. If you hold down ▲ or ▼, the bank number increases or decreases continuously.
3. If necessary, repeatedly press **MODE** to select "Motorola."
4. Press **FUNC** then **2**. The screen displays the Base, Offset, and Step with the B in Base blinking.
5. If necessary, use the number keys to enter a new Base frequency and press **ENT**. The O in Offset blinks.
6. If necessary, use the number keys to enter a new Offset frequency and press **ENT**. The S in Step blinks.

If you try to program an offset frequency in the UHF-Hi bands (806-960 MHz), the scanner ignores the entry.

-
7. While the S in Step blinks, repeatedly press ▲ or ▼ to select the step number: 5.0, 6.25, 10.0, 12.5, 15.0, 18.75, 20.0, 25.0, 30.0, 31.25, 35.0, 37.5, 40.0, 43.75, or 50.0 kHz, then press **ENT**.
 8. Press **PROG**.

UHF-Hi (806-960 MHz)

To program 800 MHz Motorola trunking:

1. Press **PROG** then **TRUNK** to enter the ID program mode.
2. Press **FUNC**, then press ▲ or ▼. The bank number increases or decreases by one. If you hold down ▲ or ▼, the bank number increases or decreases continuously.
3. If necessary, repeatedly press **MODE** to select "Motorola."
4. Press **FUNC** then **3**. **NORMAL** appears.
5. Press ▲ or ▼ to select **NORMAL** or **SPLINTER** and press **ENT**. If you are uncertain about the base frequency, use **NORMAL**.

The base frequency in **NORMAL** is 851.0125 MHz. The base frequency in **SPLINTER** is 851.0000 MHz. . If you cannot receive with the **NORMAL** setting, change to **SPLINTER**.

EDACS Trunking Setup

EDACS (GE/Ericsson) systems transmit Talk Group ID data on a dedicated control channel. Scanning requires clear reception of the control channel at all times, so *EDACS* systems generally have a smaller usable area. You can manually select the data channel, but an external antenna can greatly improve *EDACS* scanning.

If you are programming frequencies for an *EDACS* system, you must store them in the Logical Channel Number order (usually listed as LCN#).

LTR Trunking Setup

LTR systems, assign each frequency a Home Repeater (HR) number, and are frequently programmed with unique ID codes for each radio. LTR Talk Group IDs are organized in a specific order, and to scan, you must program the frequencies in HR order. LTR systems are used primarily by businesses, such as taxicabs, delivery trucks, and repair services.

LTR systems use a Home Repeater as part of their Talk Group ID.

To save a correct Home Repeater:

1. Save the LTR channels in any order.
2. Set the bank to Open mode.
3. Manually select LT channels and watch the LTR data on the display.

Your scanner displays the LTR Talk Group ID and a number preceded by "R." The "R" number is the Home Repeater number for the transmission.

4. The assigned Home Repeater channel must equal the Home Repeater number. For example, R12 must be programmed into Channel 12.

Searching for Talk Group IDs

If you tune the scanner to an active Motorola control channel, the Motorola System ID and the approximate control channel message decode success rate appears. This helps you identify the system and the reception quality. When the scanner decodes control channel data from a Motorola system, COTRL appears on the display.

To search for Talk Group IDs:

1. Set the bank to Open mode.
2. Press **SCAN**. The scanner scans through all unlocked channels in the active banks.
3. When the scanner stops on a transmission, press **TRUNK**. The scanner displays the ID location:

Sub-bank.	ID Location
0-4	00-29
Example: 2-01	

If the ID has already been saved, "ID was saved" appears.

If you try to store more than 150 talk group IDs in a bank, "Memory Full!" appears.

Saving a Talk Group ID

Each of the 10 banks contains 5 **sub-banks** that each hold 30 Talk Group IDs. (You can save up to 1,500 Talk Group IDs.) When the scanner receives a trunked transmission, it searches the associated sub-bank for the Talk Group ID to decode data for Motorola, EDACS (GE/Ericsson), and LTR (EF Johnson) systems.

To define a Talk Group ID:

1. Press **PROG**, then press **TRUNK** to enter the ID program mode.
2. Press **FUNC**, then use ▲ or ▼ to select a bank.
3. Repeatedly press **MODE** to select a trunking mode (Motorola, EDACS, or LTR).
4. Repeatedly press **TRUNK** to select the sub-bank.
5. Press ▲ or ▼ to select the location where to store the Talk Group ID.

-
6. Use the number and decimal point keys to enter the Talk Group ID:

For ED Talk Group IDs, you can enter either a decimal or AFS code. The default setting is decimal ID entry.

To use the AFS code, press **FUNC** then **2**, "AFS Format" appears for about 2 seconds. You can then enter the AFS code.

If you make a mistake, "Invalid ID value" appears when you press **ENT**. Go back to Step 3.

If you entered an ID that is already stored in same bank, "Dupl. ID of X-XX appears." To store the ID code, press **ENT**. To cancel, press **CL**.

7. Press **ENT**.

For information about adding text tags to a Talk Group ID, see "Text Tags" on Page 43.

Deleting Talk Group IDs

You can delete an individual Talk Group ID or all Talk Group IDs in a bank.

To delete a Talk Group ID:

1. Press **PROG** then **TRUNK**.
2. Press **FUNC**, **▲** or **▼** to select ID memory.
3. Press **FUNC** then **CL**.

To delete ALL talk group IDs in a bank:

1. Press **PROG**.
2. Press **TRUNK** to enter a Talk Group ID memory mode.
3. Select a Talk Group ID bank using **FUNC**, **▲** or **▼**.
4. Press **FUNC** then **6**. "Clear entire list? Press 1 to clear all, any other key aborts" appears.

-
5. To clear the Talk Group IDs, Press **1**. To cancel the deletion, press any key except **1**.

Saving Trunking Channels

Trunking channels are defined using the same procedure for non-trunking channels. In each bank, you can mix channel modes, including conventional, but you can scan only one trunking mode at a time, either EDACS, Motorola, or LTR.

Because Motorola control frequencies change daily, you should save all the control frequencies in the same bank. If you do not know the control frequency, save all the Motorola frequencies in the same bank.

EDACS frequencies are assigned Logical Channel Numbers (LCN) and organized in a specific order. To scan correctly, you must program the frequencies in LCN order, starting with Memory 01.

Trunked modes (MO, ED, and LT) can only be selected for frequencies above 137 MHz that use trunking operations.

For information about adding text tags to a channel, see "Text Tags" on Page 43.

Trunk Scanning

In each bank, you can mix conventional channels and frequencies in a bank. However, you can scan only one trunking mode at a time, either EDACS, Motorola, or LTR.

Press Scan. The scanner scans through unlocked channels in active banks. To focus on trunk scanning, you can turn off banks that contain only conventional channels. To change the scanning direction, press **▲** or **▼**.

For Motorola channels, your scanner displays the Talk Group ID memory location, received frequency, voice channel (VC), and the Motorola ID number.

Your scanner automatically mutes the audio while it decodes control channel data. However, we recommend you turn SQ clockwise and leave it set to a point just after the hiss stops. This lets the scanner quickly acquire the data channel.

For Motorola trunking systems, more than one talk group can transmit at a time. If you manually tune the scanner, you will hear the talk group on that channel, but the display will alternate between all active Talk Group IDs.

For EDACS and Motorola (above 406 MHz range), the scanner monitors the control channel between each transmission to identify talk groups. For some Motorola (under 512 MHz range) and LTR systems, the scanner uses the subaudible data sent with each transmission to identify talk groups.

Trunking Delay

You can set a Talk Group ID delay separately from the channel delay. When active, the scanner checks the Talk Group ID for the delay time when a transmission ends.

To set a Talk Group ID delay:

1. Press **FUNC** then **./DELAY** while you are programming the Trunk Group ID. "ENTER key saves. 2.0 seconds" appears.
2. Use **▲** or **▼** to set ID Delay: None, 0.5, 1.0, 1.5, 2.0, 2.5, 3.0, 3.5, or 4.0 seconds.
3. Press **ENT**.

Locking Out Talk Group IDs

You can only lock out Talk Group IDs when the scanner is in the Closed mode.

To lock out Talk Group IDs:

1. Press **PROG** then **TRUNK**.
2. Press **FUNC**, **▲** or **▼** to move to the desired bank.
3. Press **▲** or **▼** to select the ID.
4. Press **L/OUT** to lock out the ID. "lo" changes to "LO."
5. To remove the lockout from a trunking ID, manually select the ID memory, and press **L/OUT**. LO changes to lo.

You cannot clear all lockouts from a talk group at the same time.

To review locked-out Talk Group IDs:

1. Press **PROG** then **TRUNK**.
2. Press **FUNC**. Then **L/OUT**. The first locked out ID appears. If the ID memory bank has no locked-out ID, you hear the low beep tone.
3. Press **▲** or **▼** to scroll through the list.
4. Press **PROG** to exit.

Turning Off Sub-Banks

To turn off a sub-bank:

1. Press **TRUNK** repeatedly to select the desired sub-bank.
2. Press **FUNC** then **1** to turn the sub-bank on if it is off or off if it is on.

To turn off a sub-bank while scanning:

1. When the scanner stops on a transmission, press **FUNC**.
2. Press **TRUNK**. The display indicates which sub-bank is turned on or off. The active sub-bank number appears.
3. Press **FUNC** and the number of the sub-bank you desire to turn on or off. For example to turn sub-bank 4 on or off, press **FUNC**. Then press **4**.

This function activates when the receiving channel bank is Closed mode.

Talk Group ID Hold

You can set your scanner to follow a trunking signal that you want to track during scanning.

To set Talk Group ID Hold:

1. While the scanner is stopped on a voice channel (VC appears), hold down **TRUNK** until "ID hold ON" appears.

When the scanner receives a transmission, the "S" on the display changes to "H."

2. To release ID hold, press **SCAN** or **TRUNK**.

Scanner Maintenance

- Handle the scanner carefully; do not drop it.
- Use and store the scanner only in normal temperature environments.
- Keep the scanner dry; if it gets wet, wipe it dry immediately.
- Keep the scanner away from dust and dirt, and wipe it with a damp cloth occasionally to keep it looking new.

Text Tags

While scanning, if the scanner stops on a channel with a saved text tag, the text appears on the display. Otherwise, the Talk Group ID appears on the display.

You can define text tags to identify channels, Talk Group IDs, banks or FIPS Codes.

To define a Text Tag:

1. To define a text tag for a channel:
 - Press **MAN**.
 - Enter the bank and channel number.
 - Press **PROG**. M changes to P.
2. To define a text tag for a Talk Group ID:
 - Press **PROG**.
 - Press **TRUNK**.
 - Press **FUNC** then ▲ or ▼ to select the desired bank.
 - Press **TRUNK** to select the desired sub-bank.
 - Press or hold down ▲ or ▼ to select the desired group ID.
3. To define a text tag for a bank:
 - Press **PROG**.
 - Press **FUNC** then press bank number. "Bank X (0 through 9) selected" appears.
4. To define a text tag for a FIPS code, first access the FIPS code definition. See "SAME Standby Mode" on Page 28.
5. Press **TEXT**.
6. Enter the text using the text keys (up to 16 characters).

When you press a key, the associated letters appear on the 7screen. Press the corresponding number. For example, when you press ABC, A, B, and C appear on the display. To select A, press **1**. To select B, press **2**. To select C, press **3**.

To enter a number, press **1**, then press the number key.

To enter lowercase character or second-set character for the 0 key, press the number key and then press **FUNC**.

7. If you make a mistake, press ▲ or ▼ to move to the character you want to change.
8. Press **ENT** to save the text.

To display the Talk Group ID:

1. If the scanner displays the text tag for a transmission, press **TEXT**. The ID code appears.
2. Press **TEXT** again to cancel.

Troubleshooting

Issue	Solution
<p>The scanner does not function.</p> <p>Cause:</p> <p>The AC or DC adaptor might not be connected.</p> <p>If using a DC adaptor, the DC adaptor socket might be dirty.</p>	<p>Make sure the adaptor's barrel plug is fully inserted into the PWR jack. The center tip of the adaptor's barrel plug must be set to positive.</p> <p>Unplug the DC adaptor from the power source and clean the socket, or check the adaptor's internal fuse.</p>
<p>The scanner does not receive stations or reception is poor.</p> <p>Cause:</p> <p>Antenna might not be connected correctly.</p> <p>Squelch setting might be too sensitive.</p> <p>Attenuator might be on so your scanner might not receive weak signals.</p>	<p>Check the antenna.</p> <p>Check the squelch.</p> <p>Check the Attenuator.</p> <p>If these solutions do not work, turn the scanner off then on again, or initialize the scanner.</p>
<p>The scanner does not scan.</p> <p>Cause:</p> <p>The squelch might not be adjusted correctly.</p> <p>One channel or no channels stored in the scanner.</p>	<p>Turn SQ clockwise.</p> <p>Save more frequencies into channels.</p>

Issue	Solution
<p>Error message appears when trying to upload or download from a computer.</p> <p>Cause:</p> <p>Your computer is using Windows XP and does not have the necessary USB cable driver.</p>	<p>Download and install the "Windows XP Driver to resolve PC connection error" file from your scanner's Product Support page or the Software Download page on www.RadioShack.com.</p> <p>Then make your connection and try again. Be sure the correct COM port is selected in device manager..</p>

Birdie Frequencies

All scanners have signals created inside the scanner's receiver. These birdie frequencies can interfere with transmissions on the same frequencies. If the interference is not severe, you might be able to turn SQ clockwise to omit the birdie.

To find the birdies:

1. Disconnect the antenna and moving it away from the scanner. Make sure that no other nearby radio or TV sets are turned on near the scanner.
2. Start a search of every frequency range from its lowest frequency to the highest. When the search stops, often without any sound, this is a birdie.
3. Make a list of all the birdies in your scanner for future reference.

Initializing the Scanner

If the scanner's display locks up or does not work properly after you connect a power source or install batteries, you might need to initialize it.

Caution: *This procedure clears the scanner's memory. Initialize the scanner only after trying all other methods to correct issues.*

To initialize the scanner:

1. Turn off the scanner, then turn it on again. "Multi-system Trunking Scanner" appears.
2. While "Multi-system Trunking Scanner" appears, press **0**.
3. Press **1**.
4. Press **ENT**. "Initializing please stand by" appears for about 5 seconds. When the initialization is complete, M000 appears on the second line of the display. Bank 0 Ch 00 appears.

Do not turn off the scanner until the initialization is complete.

Service and Repair

If your scanner is not performing as it should, take it to your local RadioShack store for assistance. To locate your nearest RadioShack, use the store locator feature on RadioShack's web site (www.radioshack.com), or call 1-800-The Shack (800-843-7422) and follow the menu options. Modifying or tampering with the scanner's internal components can cause a malfunction and might invalidate its warranty and void your FCC authorization to operate it.

Scanning Legally

Your scanner covers frequencies used by many different groups including police and fire departments, ambulance services, government agencies, private companies, amateur radio services, military operations, pager services, and wireline (telephone and telegraph) service providers. It is legal to listen to almost every transmission your scanner can receive. However, there are some transmissions you should never intentionally listen to. These include:

- telephone conversations (cellular, cordless, or other private means of telephone signal transmission)
- pager transmissions
- any scrambled or encrypted transmissions

According to the Electronic Communications Privacy Act (ECPA), as amended, you are subject to fines and possible imprisonment for intentionally listening to, using, or divulging the contents of such a transmission unless you have the consent of a party to the communication (unless such activity is otherwise illegal).

This scanner is designed to prevent reception of illegal transmissions, in compliance with the law which requires that scanners be manufactured in such a way as to not be easily modifiable to pick up those transmissions. Do not open your scanner's case to make any modifications that could allow it to pick up transmissions that it is not legal to listen to. Doing so could subject you to legal penalties.

In some areas, mobile use of this scanner is unlawful or requires a permit. Check the laws in your area. It is also illegal in many areas to interfere with the duties of public safety officials by traveling to the scene of an incident without authorization.

We encourage responsible, legal scanner use.

FCC Notice

This equipment has been tested and found to comply with the limits for a scanning receiver, pursuant to Part 15 of the FCC Rules. These limits are designed to provide reasonable protection against harmful interference in a residential installation. This equipment generates, uses and can radiate radio frequency energy and, if not installed and used in accordance with the instructions, may cause harmful interference to radio communications.

However, there is no guarantee that interference will not occur in a particular installation. If this equipment does cause harmful interference to radio or television reception, which can be determined by turning the equipment off and on, the user is encouraged to try to correct the interference by one or more of the following measures:

- Reorient or relocate the receiving antenna.
- Increase the separation between the equipment and receiver.
- Connect the equipment into an outlet on a circuit different from that to which the receiver is connected.

References

Appendix A: Glossary

Frequency – The signal (expressed in MHz) used by broadcasting radios. To find active frequencies, you can use frequency guides available from your local RadioShack store, frequency lists posted on the Internet, or your scanner's search function.

Bank – A storage unit for a group of channels. A channel contains one frequency, and a bank can hold up to 100 channels.

Channel – A programmable memory locations for a single frequency.

Talk Group ID – A simultaneous trunking transmission that identifies 2-way radio users. This allows trunking systems to allocate a few frequencies to multiple 2-way radio users.

Sub-bank – Each bank has an associated Talk Group ID sub-bank. In Closed mode, the scanner only stops if a transmission has a Talk Group ID saved in the associated Talk Group ID sub-bank. In Open Mode, the scanner stops on all transmissions, except those you lock out.

Appendix B: Search Banks

Note: All scanners tune by steps. Your RadioShack scanner uses steps consistent with the latest US or worldwide standards. If you enter a non-valid step frequency, any scanner will tune to the next step. Some scanner designs do this without showing the correct step in the display. This scanner will show the actual tuned frequency in the display. Because steps are so close together, the audio quality will not be affected by the offset.

Search bank: SR0 Marine band

Receive mode: FM

Ch.	Freq. (MHz)	Ch.	Freq. (MHz)	Ch.	Freq. (MHz)
01	156.0500	21	157.0500	72	156.6250
05	156.2500	22	157.1000	73	156.6750
06	156.3000	23	157.1500	74	156.7250
07	156.3500	24	157.2000 161.8000	77	156.8750
08	156.4000	25	157.2500 161.8500	78	156.9250
09	156.4500	26	157.3000 161.9000	79	156.9750
10	156.5000	27	157.3500 161.9500	80	157.0250
11	156.5500	28	157.4000 162.0000	81	157.0750
12	156.6000	63	156.1750	82	157.1250

Ch.	Freq. (MHz)	Ch.	Freq. (MHz)	Ch.	Freq. (MHz)
13	156.6500	64	156.2250 160.8250	83	157.1750
14	156.7000	65	156.2750	84	157.2250 161.8250
15	156.7500	66	156.3250	85	157.2750 161.8750
16	156.8000	67	156.3750	86	157.3250 161.9250
17	156.8500	68	156.4250	87	157.3750 161.9750
18	156.9000	69	156.4750	88	157.4250
19	156.9500	70	156.5250		
20	157.0000 161.6000	71	156.5750		

Note: Some Marine frequencies assign two frequencies to one channel. For example, 157.000 and 161.600 are assigned in Channel 20.

Search bank: SR1 CB band

Receive mode: AM

Ch.	Freq. (MHz)	Ch.	Freq. (MHz)	Ch.	Freq. (MHz)
01	26.9650	15	27.1350	29	27.2950
02	26.9750	16	27.1550	30	27.3050
03	26.9850	17	27.1650	31	27.3150
04	27.0050	18	27.1750	32	27.3250
05	27.0150	19	27.1850	33	27.3350
06	27.0250	20	27.2050	34	27.3450
07	27.0350	21	27.2150	35	27.3550
08	27.0550	22	27.2250	36	27.3650
09	27.0650	23	27.2550	37	27.3750
10	27.0750	24	27.2350	38	27.3850
11	27.0850	25	27.2450	39	27.3950
12	27.1050	26	27.2650	40	27.4050

Ch.	Freq. (MHz)	Ch.	Freq. (MHz)	Ch.	Freq. (MHz)
13	27.1150	27	27.2750		
14	27.1250	28	27.2850		

Search bank: SR2 FRS/GMRS/MURS band
 Receive Mode: FM, CT, or DC

Ch.	Freq. (MHz)	Ch.	Freq. (MHz)	Ch.	Freq. (MHz)
01	462.56250	13	467.68750	25	151.94000
02	462.58750	14	467.71250	26	154.57000
03	462.61250	15	462.55000	27	154.60000
04	462.63750	16	462.57500	28	154.62500
05	462.66250	17	462.60000	29	464.50000
06	462.68750	18	462.62500	30	464.55000
07	462.71250	19	462.65000	31	467.85000
08	467.56250	20	462.67500	32	467.87500
09	467.58750	21	462.70000	33	467.90000
10	467.61250	22	462.72500	34	467.92500
11	467.63750	23	151.82000		
12	467.66250	24	151.88000		

Search bank: SR3 Public Safety band
 Receive Mode: FM, CT, or DC

Freq. (MHz)	Step (kHz)	Freq. (MHz)	Step (kHz)
Group 0		Group 2	
33.420-33.980	10	453.0375-453.9625	6.25
37.020-37.420	10	458.0375-458.9625	6.25
39.020-39.980	10	460.0125-460.6375	6.25
42.020-42.940	10	462.5500-462.7250	6.25
44.620-45.860	10	465.0125-465.6375	6.25
45.880		467.5625-467.7125	6.25
45.900		Group 3	

Freq. (MHz)	Step (kHz)	Freq. (MHz)	Step (kHz)
45.940-46.060	10	764.003125-766.996875	3.125
46.080-46.500	10	773.003125-775.996875	3.125
Group 1		794.003125-796.996875	3.125
151.820-151.940	7.5	803.003125-805.996875	3.125
153.770-154.130	7.5	Group 4	
154.145-154.445	7.5	851.0125-852.0125	12.5
154.570		852.0375-853.0375	12.5
154.600		853.0625-854.0625	12.5
154.650-154.770	7.5	854.0875-855.0875	12.5
154.785-154.950	7.5	855.1125-856.1125	12.5
155.010-155.370	7.5	856.1375-857.1375	12.5
155.415-155.700	7.5	857.1625-858.1625	12.5
155.730-156.210	7.5	858.1875-859.1875	12.5
158.730-159.210	7.5	859.2125-860.2125	12.5
166.250		860.2375-860.9875	12.5
170.150		866.0125-868.9875	12.5

Search bank: SR4 Aircraft

Receive mode: AM, FM

Group	Frequency (MHz)	Step (kHz)
0	108.000-117.99166	8.33
1	118.000-136.99166	8.33
2	138.000-143.9875	12.5
	148.000-150.7875	12.5
3	225.000-379.975	25
	380.000-400.000	12.5

Search bank: SR5 Amateur band

Receive mode: FM, CT, or DC

Group	Frequency (MHz)	Step (kHz)
0	28.0000-29.7000	5
1	50.0000-54.0000	5
2	144.0000-148.0000	5
3	222.0000-224.9950	5
4	420.0000-450.0000	5
5	902.000-927.9875	12.5
6	1240.0000-1300.0000	6.25

Search bank: SR6 Railroad
 Receive mode: FM, CT, or DC

Frequency (MHz)	Step (kHz)
159.810-161.5650	7.5

Search bank: SR7 Programmable limit search
 Receive mode: FM, AM, CT, or DC

Appendix C: CTCSS / DCS Codes

You can program any of the following codes:

CTCSS Codes:

67.0 Hz	94.8 Hz	131.8 Hz	171.3 Hz	203.5 Hz
69.3 Hz	97.4 Hz	136.5 Hz	173.8 Hz	206.5 Hz
71.9 Hz	100.0 Hz	141.3 Hz	177.3 Hz	210.7 Hz
74.4 Hz	103.5 Hz	146.2 Hz	179.9 Hz	218.1 Hz
77.0 Hz	107.2 Hz	151.4 Hz	183.5 Hz	225.7 Hz
79.7 Hz	110.9 Hz	156.7 Hz	186.2 Hz	229.1 Hz
82.5 Hz	114.8 Hz	159.8 Hz	189.9 Hz	233.6 Hz
85.4 Hz	118.8 Hz	162.2 Hz	192.8 Hz	241.8 Hz
88.5 Hz	123.0 Hz	165.5 Hz	196.6 Hz	250.3 Hz
91.5 Hz	127.3 Hz	167.9 Hz	199.5 Hz	254.1 Hz

DCS Codes:

006	050	125	174	255	343	445	526	703
007	051	131	205	261	346	446	532	712
015	053	132	212	263	351	452	546	723
017	054	134	214	265	356	454	565	731
021	065	141	223	266	364	455	606	732
023	071	143	225	271	365	462	612	734
025	072	145	226	274	371	464	624	743
026	073	152	243	306	411	465	627	754
031	074	155	244	311	412	466	631	
032	114	156	245	315	413	503	632	
036	115	162	246	325	423	506	654	
043	116	165	251	331	431	516	662	
047	122	172	252	332	432	523	664	

Appendix D: Signal Stalker

Signal Stalker can search the following bands:

All Band

Bnk.	Freq. (MHz)	Bnk.	Freq. (MHz)
0	25.000-54.000	5	406.000-470.000
1	108.000-136.99166	6	470.0125-512.000
2	137.000-174.000	7	764.000-805.996875
3	216.0025-299.975	8	806.000-868.9875
4	300.000-405.9875	9	894.000-960, 1240-1300.000

PubSafety Band

Freq. (MHz)	Step (kHz)	Freq. (MHz)	Step (kHz)
Group 0		Group 2	
33.420-33.980	10	453.0375-453.9625	6.25
37.020-37.420	10	458.0375-458.9625	6.25
39.020-39.980	10	460.0125-460.6375	6.25
42.020-42.940	10	462.5500-462.7250	6.25
44.620-45.860	10	465.0125-465.6375	6.25
45.880		467.5625-467.7125	6.25
45.900		Group 3	
45.940-46.060	10	764.003125-766.996875	3.125
46.080-46.500	10	773.003125-775.996875	3.125
Group 1		794.003125-796.996875	3.125
151.820-151.940	7.5	803.003125-805.996875	3.125
153.770-154.130	7.5	Group 4	
154.145-154.445	7.5	851.0125-852.0125	12.5
154.570		852.0375-853.0375	12.5
154.600		853.0625-854.0625	12.5
154.650-154.770	7.5	854.0875-855.0875	12.5
154.785-154.950	7.5	855.1125-856.1125	12.5
155.010-155.370	7.5	856.1375-857.1375	12.5
155.415-155.700	7.5	857.1625-858.1625	12.5
155.730-156.210	7.5	858.1875-859.1875	12.5
158.730-159.210	7.5	859.2125-860.2125	12.5
166.250		860.2375-860.9875	12.5
170.150		866.0125-868.9875	12.5

Appendix E: Talk Group Format

Motorola

For **Motorola Type I**, enter the block number, fleet number and subfleet number.

Fleet No.	Subfleet No.
XXX	XX
Example: XXX-XX	

Motorola Type II talk group IDs are 4- or 5-digit numbers, divisible by 16.

EDACS

Enter either a four-digit **decimal** number from 0001 to 2047.

Agency Fleet Subfleet (AFS) numbers range from 00-001 to 15-157. The default EDACS setting is decimal.

To use AFS format:

1. Press **FUNC** then **2**. "AFS Format" appears briefly.
2. Enter the AFS number:

Agency No.	Fleet No.	Subfleet No.
XX	XXXX	XXXX
Example: XXXXXX-XXXX		

LTR

Enter the area code, home repeater and user ID.

Area Code	Home Repeater	User ID
0-1	01-20	000-254
Example: 010123		

Appendix F: Specifications

Frequency Coverage:

25.000-26.960 MHz	(in 10 kHz steps/AM)
26.965-27.405 MHz	(in 10 kHz steps/AM)
27.410-29.505 MHz	(in 5 kHz steps/AM)
29.510-29.700 MHz	(in 5 kHz steps/FM)
29.710-49.830 MHz	(in 10 kHz steps/FM)
49.835-54.000 MHz	(in 5 kHz steps/FM)
108.000-136.9916 MHz	(in 8.33 kHz steps/AM)
137.000-137.995 MHz	(in 5 kHz steps/FM)
138.000-143.9875 MHz	(in 12.5 kHz steps/FM)
144.000-147.995 MHz	(in 5 kHz steps/FM)
148.000-150.7875 MHz	(in 12.5 kHz steps/FM)
150.800-150.845 MHz	(in 5 kHz steps/FM)
150.8525-154.4975 MHz	(in 7.5 kHz steps/FM)
154.515-154.640 MHz	(in 5 kHz steps/FM)
154.650-156.255 MHz	(in 7.5 kHz steps/FM)
156.275-157.450 MHz	(in 25 kHz steps/FM)
157.470-161.5725 MHz	(in 7.5 kHz steps/FM)
161.600-161.975 MHz	(in 5 kHz steps/FM)
162.000-174.000 MHz	(in 12.5 kHz steps/FM)
216.0025-219.9975 MHz	(in 5 kHz steps/FM)
220.000-224.995 MHz	(in 5 kHz steps/FM)
225.000-379.975 MHz	(in 25 kHz steps/AM)
380.000-419.9875 MHz	(in 12.5 kHz steps/FM)
420.000-450.000 MHz	(in 5 kHz steps/FM)
450.00625-469.99375 MHz	(in 6.25 kHz steps/FM)
470.000-512.000 MHz	(in 12.5 kHz steps/FM)
764.000-766.996875 MHz	(in 3.125 kHz steps/FM)
773.000-775.996875 MHz	(in 3.125 kHz steps/FM)
794.000-796.996875 MHz	(in 3.125 kHz steps/FM)
803.000-805.996875 MHz	(in 3.125 kHz steps/FM)
806.000-823.9875 MHz	(in 12.5 kHz steps/FM)
849.000-868.9875 MHz	(in 12.5 kHz steps/FM)
894.000-939.9875 MHz	(in 12.5 kHz steps/FM)
940.000-960.000 MHz	(in 6.25 kHz steps/FM)
1240.000-1300.000 MHz	(in 6.25 kHz steps/FM)
Memory Channels / Banks	1000 / 10
Talk group ID memories	1,500
ID memory banks / Sub-banks	10 / 5
Number of memory IDs per sub-bank	30
Sensitivity (20 dB S/N):	
FM:	
25-54 MHz	0.3 uV
108-136.99166 MHz	0.3 uV
137-174 MHz	0.5 uV

216.0025–224.975MHz.....	0.5 uV
225-299.975 MHz	0.5 uV
300-405.975 MHz	0.8 uV
406–512 MHz.....	0.5 uV
764–960 MHz.....	0.7 uV
1240–1300 MHz.....	0.7 uV
AM:	
25–54 MHz.....	1 uV
108–136.99166 MHz.....	1 uV
137–174 MHz.....	1.5 uV
216.0025–224.975MHz.....	1.5 uV
225-299.975 MHz	2 uV
300-405.975 MHz	3 uV
406–512 MHz.....	2 uV
764–960 MHz.....	2 uV
1240–1300 MHz.....	3 uV
Selectivity:	
All AM and FM (except AM 25 – 27.995 MHz).....	6 dB +/-8 kHz
.....	-50 dB +/-17 kHz
AM 25 – 27.995 MHz.....	-6 dB +/-4 kHz
.....	-50 dB +/-6 kHz
Spurious Rejection (at 154.1 MHz FM).....	40 dB
Scanning Rate	Up to 60 Channels per Second
Search Rate	Up to 78 Steps per Second
Delay Time	2 seconds
Intermediate Frequencies (IF):	
1st.....	380.8 MHz
2nd	21.4 MHz
3rd.....	455 kHz
Priority Sampling	2 seconds
Operating Temperature	-14 to 140° F(-20 to 60° C)
IF Rejection	
380.8 MHz at 154.1 MHz.....	60 dB
21.4 MHz at 154.1 MHz.....	100 dB
Squelch Sensitivity:	
Threshold (FM and AM)	0.5 uV
Tight (FM)	25 dB
Tight (AM)	20 dB
Antenna Impedance.....	50 Ohms
Audio Output Power (10% THD)	1.5W
Built-in Speaker.....	3 Inches (77 mm)(8-ohm, Dynamic Type)
Power Requirements	13.8V
Current Drain (Squelched)	200 mA
Dimensions (HWD)	2 1/4 x 7 1/4 x 5 5/16 Inches (55 x 185 x 135 mm)
Weight (without antenna).....	27.7 oz. (790 g)

Specifications and depictions are subject to change and improvement without notice.
Actual product may vary from the images found in this document.

ADDENDUM

Cat. No. 20-163 / 20-164

Preprogrammed Frequencies

Your scanner has 155 preprogrammed frequencies in the ROM. You can load them into Channels 000 to 154.

1. Turn off the scanner and then turn it on again.
2. When *Multi-system Trunking Scanner* appears, press **PGM** (or **PROG**).
3. Press **1**.

CH	Base	Licensee	Text Tag
000	40.5000	ARMY SEARCH/RESCUE	ARMY SRCH/RESCUE
001	52.5250	AMATEUR 6 METER CALLING	AMATEUR 6M CALL
002	121.5000	AIRCRAFT EMERGENCY CHANNEL	AIR EMERGENCY
003	122.0000	FLIGHT WEATHER	FLIGHT WEATHER
004	122.2000	FLIGHT SERVICE	FLIGHT SERVICE
005	122.7000	SMALL AIRPORT UNICOM CHANNEL	SMALL AIRPORT
006	122.7500	GOVERNMENT AIR TO AIR	GOVT AIR 2 AIR
007	122.8000	SMALL AIRPORT UNICOM CHANNEL	SMALL AIRPORT
008	122.9000	GOVERNMENT AIR	GOVERNMENT AIR
009	122.9500	AIRCRAFT UNICOM CHANNEL	AIRCRAFT UNICOM
010	123.0000	AIRCRAFT UNICOM CHANNEL	AIRCRAFT UNICOM
011	123.1000	AIR SEARCH/RESCUE	AIR SRCH/RESCUE
012	123.4500	PILOTS - AIR-TO-AIR	PILOTS AIR 2 AIR
013	131.4500	CAREFLIGHT	CAREFLIGHT
014	131.6750	CAREFLIGHT	CAREFLIGHT
015	146.5200	AMATEUR 2 METER CALLING	HAM 2M CALLING
016	146.7600	AMATEUR 2 METER REPEATER	HAM 2M REPEATER
017	146.8800	AMATEUR 2 METER REPEATER	HAM 2M REPEATER
018	146.9400	AMATEUR 2 METER REPEATER	HAM 2M REPEATER
019	148.1500	CIVIL AIR PATROL	CIVIL AIR PATROL
020	151.6250	RED DOT - BUSINESS BAND	RED DOT - BB

021	151.9550	PURPLE DOT - BUSINESS BAND	PURPLE DOT - BB
022	154.0100	FIRE DEPARTMENTS	FIRE DEPARTMENT
023	154.0700	FIRE DEPARTMENTS	FIRE DEPARTMENT
024	154.1300	FIRE DEPARTMENTS	FIRE DEPARTMENT
025	154.1450	FIRE DEPARTMENTS	FIRE DEPARTMENT
026	154.1600	FIRE DEPARTMENTS	FIRE DEPARTMENT
027	154.1750	FIRE DEPARTMENTS	FIRE DEPARTMENT
028	154.1900	FIRE DEPARTMENTS	FIRE DEPARTMENT
029	154.2050	FIRE DEPARTMENTS	FIRE DEPARTMENT
030	154.2200	FIRE DEPARTMENTS	FIRE DEPARTMENT
031	154.2350	FIRE DEPARTMENTS	FIRE DEPARTMENT
032	154.2500	FIRE DEPARTMENTS	FIRE DEPARTMENT
033	154.2650	FIRE DEPARTMENTS	FIRE DEPARTMENT
034	154.2800	FIRE DEPARTMENTS	FIRE DEPARTMENT
035	154.2950	FIRE DEPARTMENTS	FIRE DEPARTMENT
036	154.3100	FIRE DEPARTMENTS	FIRE DEPARTMENT
037	154.3250	FIRE DEPARTMENTS	FIRE DEPARTMENT
038	154.3400	FIRE DEPARTMENTS	FIRE DEPARTMENT
039	154.3550	FIRE DEPARTMENTS	FIRE DEPARTMENT
040	154.3700	FIRE DEPARTMENTS	FIRE DEPARTMENT
041	154.3850	FIRE DEPARTMENTS	FIRE DEPARTMENT
042	154.4000	FIRE DEPARTMENTS	FIRE DEPARTMENT
043	154.4150	FIRE DEPARTMENTS	FIRE DEPARTMENT
044	154.4300	FIRE DEPARTMENTS	FIRE DEPARTMENT
045	154.4450	FIRE DEPARTMENTS	FIRE DEPARTMENT
046	154.5700	BLUE DOT - BUSINESS BAND	BLUE DOT - BB
047	154.6000	GREEN DOT - BUSINESS BAND	GREEN DOT - BB
048	155.1600	PUBLIC SAFETY SERVICES	PUBLIC SAFETY
049	155.1750	PUBLIC SAFETY SERVICES	PUBLIC SAFETY
050	155.2050	PUBLIC SAFETY SERVICES	PUBLIC SAFETY
051	155.2200	PUBLIC SAFETY SERVICES	PUBLIC SAFETY
052	155.2350	PUBLIC SAFETY SERVICES	PUBLIC SAFETY
053	155.2650	PUBLIC SAFETY SERVICES	PUBLIC SAFETY

054	155.2800	PUBLIC SAFETY SERVICES	PUBLIC SAFETY
055	155.2950	PUBLIC SAFETY SERVICES	PUBLIC SAFETY
056	155.3250	PUBLIC SAFETY SERVICES	PUBLIC SAFETY
057	155.3400	PUBLIC SAFETY SERVICES	PUBLIC SAFETY
058	155.3550	PUBLIC SAFETY SERVICES	PUBLIC SAFETY
059	155.3700	POLICE DEPARTMENTS	POLICE DEPT.
060	155.3850	PUBLIC SAFETY SERVICES	PUBLIC SAFETY
061	155.4000	PUBLIC SAFETY SERVICES	PUBLIC SAFETY
062	155.4750	POLICE DEPARTMENTS	POLICE DEPT.
063	156.4250	MARINE CH 68 - LOCAL BOATS	MARINE CH 68
064	156.4500	MARINE CH 9 - BOATER CALLING	MARINE CH 9
065	156.4750	MARINE CH 69 - LOCAL BOATS	MARINE CH 69
066	156.5750	MARINE CH 71 - LOCAL BOATS	MARINE CH 71
067	156.6250	MARINE CH 72 - LOCAL BOATS	MARINE CH 72
068	156.8000	MARINE CH 16 CALLING/EMERGENCY	MARINE CH 16
069	156.9250	MARINE CH 78 - LOCAL BOATS	MARINE CH 78
070	157.0500	COAST GUARD	COAST GUARD
071	157.1000	COAST GUARD	COAST GUARD
072	157.1250	COAST GUARD	COAST GUARD
073	157.4250	MARINE CH 88 - COMM'L BOATS	MARINE CH 88
074	162.3000	US MARSHALLS	US MARSHALL
075	163.2000	US MARSHALLS	US MARSHALL
076	415.2000	FEDERAL PROTECTIVE SERVICE	FEDERAL SERVICE
077	415.7000	AIR FORCE ONE (PHONE PATCH)	AIR FORCE ONE
078	446.0000	AMATEUR 70CM CALLING FREQ	HAM 70CM CALLING
079	450.8000	GOODYEAR AIRSHIP TV BCST & OTH	GOODYEAR AIRSHIP

080	454.0000	NASCAR TRACK ANNOUNCER	NASCAR TRACK
081	460.0250	POLICE DEPARTMENTS	POLICE DEPT.
082	460.0500	POLICE DEPARTMENTS	POLICE DEPT.
083	460.0750	POLICE DEPARTMENTS	POLICE DEPT.
084	460.1000	POLICE DEPARTMENTS	POLICE DEPT.
085	460.1250	POLICE DEPARTMENTS	POLICE DEPT.
086	460.1500	POLICE DEPARTMENTS	POLICE DEPT.
087	460.1750	POLICE DEPARTMENTS	POLICE DEPT.
088	460.2000	POLICE DEPARTMENTS	POLICE DEPT.
089	460.2250	POLICE DEPARTMENTS	POLICE DEPT.
090	460.2500	POLICE DEPARTMENTS	POLICE DEPT.
091	460.2750	POLICE DEPARTMENTS	POLICE DEPT.
092	460.3000	POLICE DEPARTMENTS	POLICE DEPT.
093	460.3250	POLICE DEPARTMENTS	POLICE DEPT.
094	460.3500	POLICE DEPARTMENTS	POLICE DEPT.
095	460.3750	POLICE DEPARTMENTS	POLICE DEPT.
096	460.4000	POLICE DEPARTMENTS	POLICE DEPT.
097	460.4250	POLICE DEPARTMENTS	POLICE DEPT.
098	460.4500	POLICE DEPARTMENTS	POLICE DEPT.
099	460.4750	POLICE DEPARTMENTS	POLICE DEPT.
100	460.5000	POLICE DEPARTMENTS	POLICE DEPT.
101	460.5250	POLICE/FIRE/SAFETY	POLICE/FIRE/SAFE
102	460.5500	POLICE/FIRE/SAFETY	POLICE/FIRE/SAFE
103	460.5750	POLICE/FIRE/SAFETY	POLICE/FIRE/SAFE
104	460.6000	POLICE/FIRE/SAFETY	POLICE/FIRE/SAFE
105	460.6250	POLICE/FIRE/SAFETY	POLICE/FIRE/SAFE
106	460.6500	AIRLINE COMPANIES AT AIRPORT	AIRLINE COMPANY
107	460.7000	AIRLINE COMPANIES AT AIRPORT	AIRLINE COMPANY
108	460.7500	AIRLINE COMPANIES AT AIRPORT	AIRLINE COMPANY
109	460.8000	AIRLINE COMPANIES AT AIRPORT	AIRLINE COMPANY

110	460.8500	AIRLINE COMPANIES AT AIRPORT	AIRLINE COMPANY
111	460.9000	SECURITY ALARM COMPANIES	SECURITY COMPANY
112	460.9250	SECURITY ALARM COMPANIES	SECURITY COMPANY
113	460.9500	SECURITY ALARM COMPANIES	SECURITY COMPANY
114	460.9750	SECURITY ALARM COMPANIES	SECURITY COMPANY
115	462.5500	GMRS REPEATER OUTPUT 1	GMRS REPEATER 1
116	462.5625	FRS CH 1	FRS CHANNEL 1
117	462.5750	GMRS REPEATER OUTPUT 2	GMRS REPEATER 2
118	462.5875	FRS CH 2	FRS CHANNEL 2
119	462.6000	GMRS REPEATER OUTPUT 3	GMRS REPEATER 3
120	462.6125	FRS CH 3	FRS CHANNEL 3
121	462.6250	GMRS REPEATER OUTPUT 4	GMRS REPEATER 4
122	462.6375	FRS CH 4	FRS CHANNEL 4
123	462.6500	GMRS REPEATER OUTPUT 5	GMRS REPEATER 5
124	462.6625	FRS CH 5	FRS CHANNEL 5
125	462.6750	GMRS REPEATER OUTPUT 6, EMERG.	GMRS REPEATER 6
126	462.6875	FRS CH 6	FRS CHANNEL 6
127	462.7000	GMRS REPEATER OUTPUT 7	GMRS REPEATER 7
128	462.7125	FRS CH 7	FRS CHANNEL 7
129	462.7250	GMRS REPEATER OUTPUT 8	GMRS REPEATER 8
130	462.9500	PUBLIC SAFETY SERVICES	PUBLIC SAFETY
131	462.9750	PUBLIC SAFETY SERVICES	PUBLIC SAFETY
132	464.5000	BROWN DOT - BUSINESS BAND	BROWN DOT - BB
133	464.5500	YELLOW DOT - BUSINESS BAND	YELLOW DOT - BB
134	464.8750	DALE EARNHARDT JR - NASCAR	EARNHARDT JR
135	467.0625	JEFF GORDON - NASCAR	JEFF GORDON
136	467.5625	FRS CH 8	FRS CHANNEL 8
137	467.5875	FRS CH 9	FRS CHANNEL 9

138	467.6125	FRS CH 10	FRS CHANNEL 10
139	467.6375	FRS CH 11	FRS CHANNEL 11
140	467.6625	FRS CH 12	FRS CHANNEL 12
141	467.6875	FRS CH 13	FRS CHANNEL 13
142	467.7125	FRS CH 14	FRS CHANNEL 14
143	467.7625	J DOT - BUSINESS BAND	J DOT - BB
144	467.8125	K DOT - BUSINESS BAND	K DOT - BB
145	467.8500	SILVER DOT - BUSINESS BAND	SILVER DOT - BB
146	467.8750	GOLD STAR - BUSINESS BAND	GOLD STAR - BB
147	467.9000	RED STAR - BUSINESS BAND	RED STAR - BB
148	469.5000	BUSINESS BAND	BUSINESS BAND
149	469.5500	BUSINESS BAND	BUSINESS BAND
150	151.8200		MURS 1
151	151.8800		MURS 2
152	151.9400		MURS 3
153	154.5700		MURS 4
154	154.6000		MURS 5

GE-07D-3340
10A07
Printed in China

Limited One-year Warranty

This product is warranted by **RadioShack** against manufacturing defects in material and workmanship under normal use for one (1) year from the date of purchase from **RadioShack** company-owned stores and authorized **RadioShack** franchisees and dealers. For complete warranty details and exclusions, check with your local **RadioShack** store.

RadioShack Customer Relations
300 RadioShack Circle, Fort Worth, TX 76102

04/04

Motorola, Smartnet, ASTRO and Privacy Plus are registered trademarks of Motorola Inc.
EDACS is a registered trademark of M/A-COM Inc.
LTR is a registered trademark of EF Johnson.

20-163
Printed in China
GE-07D-3260
10A07

©2007. **RadioShack** Corporation.
All rights reserved. **RadioShack** and **RadioShack.com** are trademarks used by **RadioShack** Corporation.